

TECHNICAL SPECIFICATION

This Montigo commercial fireplace and its associated components are part of a custom engineered system.

This system is available with COOL-Pack or Power COOL-Pack cool-touch glass technology, which is ideal for public use applications and residential common or entertaining areas. All systems are power vented with multiple options available and are tested and certified to current ANSI Standards with CSA International US and Canada.

All Montigo commercial fireplace systems are highly customizable. Please contact Montigo to confirm if your installation requirements are within the parameters of these standard specifications.

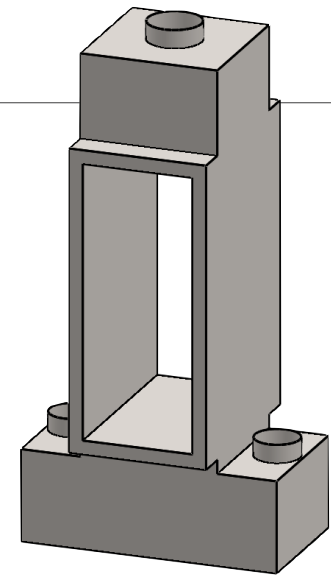

GLASS **GLASS DIMENSIONS CAN BE CUSTOMIZED**

Glass Width: 24"

Glass Height: 60"

Glass Type: 5 mm or 6 mm thick tempered glass (standard)
8 mm tempered glass available (optional)

Laminated safety glass standard on units > 96" tall

No Glass: Open units are available

GLASS TEMPERATURE

COOL-Pack < 172°F†

Power COOL-Pack Up to a 60°F reduction†

TYPICAL INTAKE

Intake Size: 14" / 154 sq.in. min.

Intake Location: Side

Intake Damper: Optional, tied into control system

TYPICAL EXHAUST

Power Vent: Montigo roof mount, wall mount, flush wall mount, or inline power vent, sized to specific system

Flue Size: 12" / 113 sq.in. min. type B vent, any manufacturer UL/ULC certified, may need to be upsized to specific system

Flue Damper: Optional flue damper, built into power vent or inline tied into control system

GAS

Rating Input: Estimated 145,000 BTU/hr

Minimum Inlet Pressure: 5.5" w.c. Natural Gas / 11" w.c. Propane

Gas System: ½" NPT, Hot Surface Ignition, Smart Valve

Tornado Burner

CONSTRUCTION

Satin galvanized (black) or stainless steel

CONSUMPTION SETTING

Consumption settings are rough estimates only and vary depending on vent runs, field conditions and other factors. Please contact Montigo if you require an estimated consumption for your specific project utilizing room air.

ELECTRICAL

Standalone custom control panel mounted within 150' of fireplace, 208-240 VAC w Neutral, AMP rating depends on actual spec

BURNER MEDIA

Glass media

OPTIONS

Uplighting, downlighting, lighting remote control, black reflective glass, decorative liners, custom logo/artwork‡

TESTING STANDARDS

ANSI Z21.50/ CSA 2.22-2016, ANSI Z21.97/ CSA 2.41-2017

† Actual glass temperature will vary based on BTU, vent run configuration, fireplace size, utilized media and panels, ambient temperature and other factors

‡ Inquire on your specific project

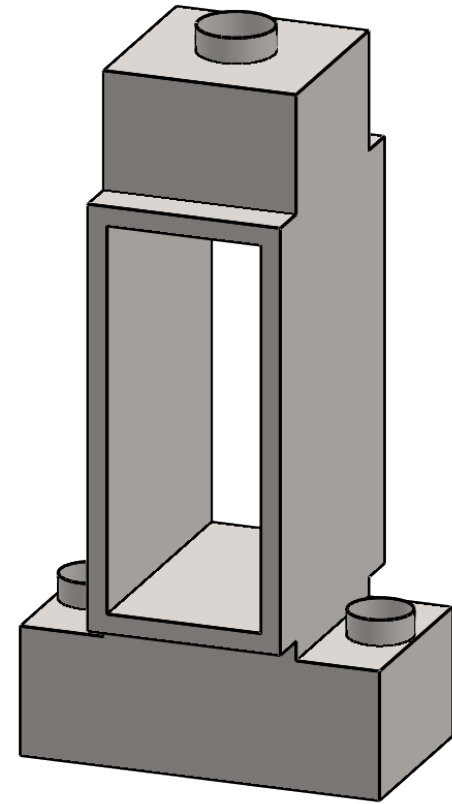
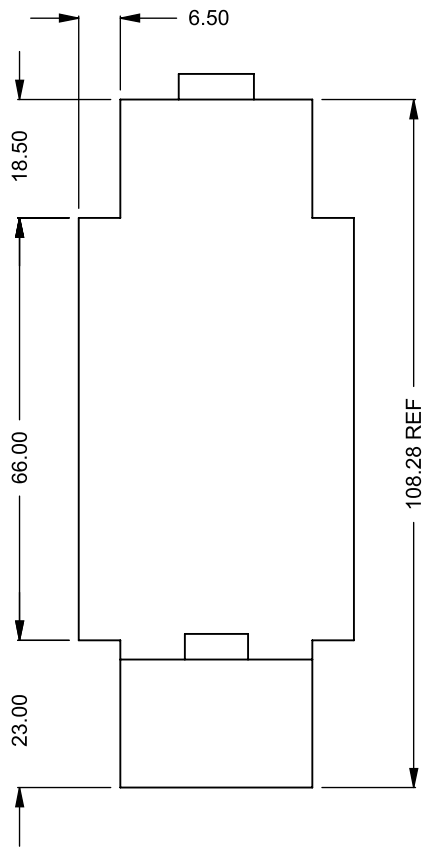
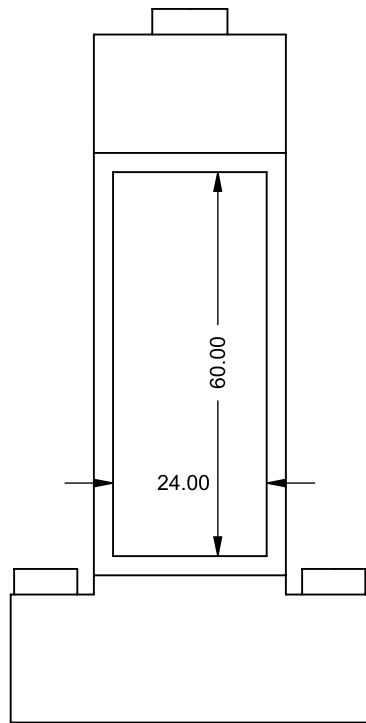
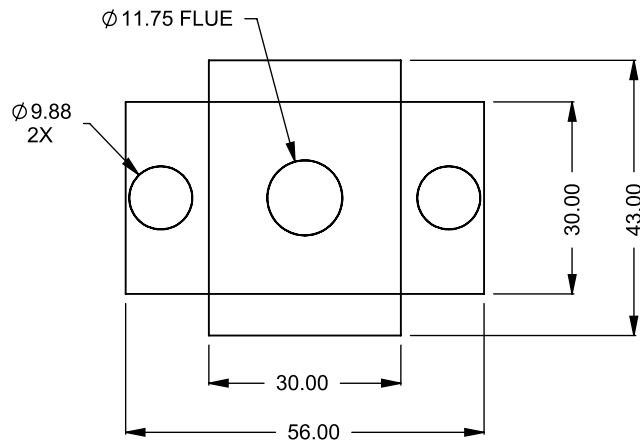

T260ST
Power COOL-Pack
Side Intake

**PRELIMINARY
DRAWING ONLY** 

EXAMPLE CONFIGURATION	UNLESS OTHERWISE SPECIFIED	DATE
<p>MONTIGO COMMERCIAL FIREPLACES ARE CUSTOM BUILT FOR EACH PROJECT. THIS DRAWING IS FOR REFERENCE ONLY.</p> <p>FLUE AND AIR INTAKE SIZES ARE SUBJECT TO CHANGE DEPENDING ON VENT RUN.</p>	<p>DIMENSIONS ARE IN INCHES TOLERANCES: FRACTIONAL $\pm 1/8"$</p>	<p>26/05/2021</p>

MONTIGO
the art of **fireplaces**
www.montigo.com